

# 2/2

VALVES FOR DRY OR LUBRICATED AIR, NEUTRAL GASES AND LIQUIDS  
PILOT OPERATED

BRASS

PIPE MOUNTING

NORMALLY OPEN

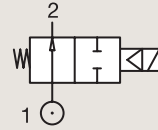

Port size (BSP)	Orifice Ø mm	Flow factors			Operating Pressure Differential Max(MOPD)			Fluid Temp. °C		Seat Seal	Valve Ref.	Housing Ref.	Coil Ref.	Power		Coil Group	Dwg. No.
		Kv l/min	KV m³/h	Qn m³/h	Min bar	AC bar	DC bar	Min °C	Max °C					AC W	DC W		
		1600	1600	1600	0.3	40	25	-10	100					NBR	322H71 <sub>12</sub>		
1/4"	8	36	2.16	1600	0.3	40	30	-10	100	NBR	322H71 <sub>12</sub>	4270	481000	8	8	2.0	3523
	8	36	2.16	1600	0.3	40	40	-10	100	NBR	322H71 <sub>12</sub>	4270	486265	14	14	2.0	3523
	8	36	2.16	1600	0.3	40	40	-10	100	FKM	322H7106 <sub>12</sub>	2995	481865	8	9	2.0/14.1	3523
	8	36	2.16	1600	0.3	40	40	-10	120	FKM	322H7106 <sub>12</sub>	4270	481000	8	8	2.0/14.1	3523
	8	36	2.16	1600	0.3	40	40	-10	140	FKM	322H7106 <sub>12</sub>	4270	486265	14	14	2.0/14.1	3523
	8	36	2.16	1600	0.3	40	40	-10	140	FKM	322H7106 <sub>12</sub>	4270	486265	14	14	2.0/14.1	3523
3/8"	11	50	3	3240	0.3	40	40	-10	75	NBR	322H73 <sub>12</sub>	2995	481865	8	9	2.0	3523
	11	50	3	3240	0.3	40	40	-10	75	NBR	322H73 <sub>12</sub>	4270	481000	8	8	2.0	3523
	11	50	3	3240	0.3	40	40	-10	75	NBR	322H73 <sub>12</sub>	4270	486265	14	14	2.0	3523
	11	50	3	3240	0.3	40	40	-10	100	FKM	322H7306 <sub>12</sub>	2995	481865	8	9	2.0/14.1	3523
	11	50	3	3240	0.3	40	40	-10	100	FKM	322H7306 <sub>12</sub>	4270	481000	8	8	2.0/14.1	3523
	11	50	3	3240	0.3	40	40	-10	140	FKM	322H7306 <sub>12</sub>	4270	486265	14	14	2.0/14.1	3523
1/2"	15	60	3.6	3890	0.3	15	15	-10	100	NBR	322G75	2995	481865	8	9	2.1	3522
	15	60	3.6	3890	0.3	15	15	-10	100	NBR	322G75	4270	481000	8	8	2.1	3522
	15	60	3.6	3890	0.3	20	20	-10	100	FKM	322G7506 <sub>1</sub>	2995	481865	8	9	2.0	3522
	15	60	3.6	3890	0.3	20	20	-10	100	FKM	322G7506 <sub>1</sub>	4270	481000	8	8	2.0	3522
	15	60	3.6	3890	0.3	20	20	-10	100	FKM	322G7506 <sub>1</sub>	4270	486265	14	14	2.0	3522
	15	60	3.6	3150	1.5	40	40	-10	50	PUR	322H35 <sub>3</sub>	2995	481865	8	9	2.1	7569
	15	60	3.6	3150	1.5	40	40	-10	50	PUR	322H35 <sub>3</sub>	4270	481000	8	8	2.1	7569
	15	60	3.6	3890	0.3	40	40	-10	100	NBR	322H75 <sub>12</sub>	2995	481865	8	9	2.0	3522
	15	60	3.6	3890	0.3	40	40	-10	100	NBR	322H75 <sub>12</sub>	4270	481000	8	8	2.0	3522
	15	60	3.6	3890	0.3	40	40	-10	100	NBR	322H75 <sub>12</sub>	4270	486265	14	14	2.0	3522
	15	60	3.6	3890	0.3	40	40	-10	100	FKM	322H7506 <sub>12</sub>	2995	481865	8	9	2.0/14.1	3522
	15	60	3.6	3890	0.3	40	40	-10	120	FKM	322H7506 <sub>12</sub>	4270	481000	8	8	2.0/14.1	3522
	15	60	3.6	3890	0.3	40	40	-10	140	FKM	322H7506 <sub>12</sub>	4270	486265	14	14	2.0/14.1	3522

Notes:

1. Minimum pressure differential = 0.3 bar for opening and 0 bar for closing
2. Pilot seat disc in synthetic Ruby
3. Valve only compatible with air and neutral gases



For this page	Port size	Orifice (mm)	Kv (l/min)	MOPD (bar)	Fluid Temp (°C)
From	1/4"	8	36	15	-10
To	1/2"	15	60	40	140

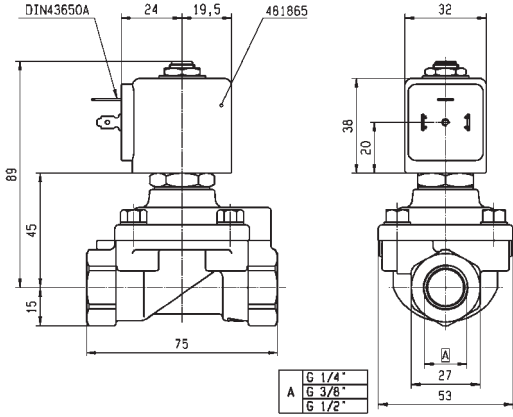

Drawing 3523

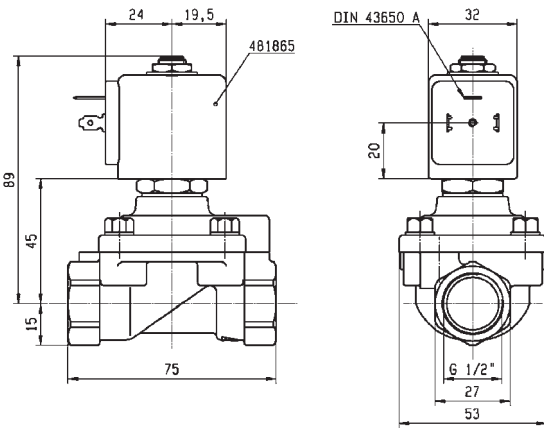

Drawing 3522

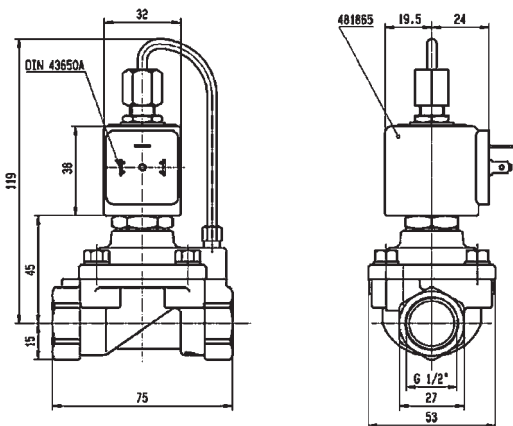

Drawing 7569